

## About this Manual

We've added this manual to the Agilent website in an effort to help you support your product. This manual is the best copy we could find; it may be incomplete or contain dated information. If we find a more recent copy in the future, we will add it to the Agilent website.

## Support for Your Product

Agilent no longer sells or supports this product. Our service centers may be able to perform calibration if no repair parts are needed, but no other support from Agilent is available. You will find any other available product information on the Agilent Test & Measurement website, [www.tm.agilent.com](http://www.tm.agilent.com).

## HP References in this Manual

This manual may contain references to HP or Hewlett-Packard. Please note that Hewlett-Packard's former test and measurement, semiconductor products and chemical analysis businesses are now part of Agilent Technologies. We have made no changes to this manual copy. In other documentation, to reduce potential confusion, the only change to product numbers and names has been in the company name prefix: where a product number/name was HP XXXX the current name/number is now Agilent XXXX. For example, model number HP8648A is now model number Agilent 8648A.

---

# User's and Service Guide

---

HP 86200B 50 $\Omega$  and  
HP 86201B 75 $\Omega$   
RF Detectors

HP part number: 86200-90015 Supersedes: February 1995  
Printed in USA October 1996

**Notice.**

The information contained in this document is subject to change without notice.

Hewlett-Packard makes no warranty of any kind with regard to this material, including but not limited to, the implied warranties of merchantability and fitness for a particular purpose. Hewlett-Packard shall not be liable for errors contained herein or for incidental or consequential damages in connection with the furnishing, performance, or use of this material.

©Copyright Hewlett-Packard Company 1995, 1996  
All Rights Reserved. Reproduction, adaptation, or translation without prior written permission is prohibited, except as allowed under the copyright laws.  
1400 Fountaingrove Parkway, Santa Rosa, CA 95403-1799, USA

---

## Certification

Hewlett-Packard Company certifies that this product met its published specifications at the time of shipment from the factory. Hewlett-Packard further certifies that its calibration measurements are traceable to the United States National Institute of Standards and Technology, to the extent allowed by the Institute's calibration facility, and to the calibration facilities of other International Standards Organization members.

---

# Warranty

This Hewlett-Packard product is warranted against defects in material and workmanship for a period of one year from date of shipment. During the warranty period, Hewlett-Packard Company will, at its option, either repair or replace products which prove to be defective.

For warranty service or repair, this product must be returned to a service facility designated by Hewlett-Packard. Buyer shall prepay shipping charges to Hewlett-Packard and Hewlett-Packard shall pay shipping charges to return the product to Buyer. However, Buyer shall pay all shipping charges, duties, and taxes for products returned to Hewlett-Packard from another country.

Hewlett-Packard warrants that its software and firmware designated by Hewlett-Packard for use with an instrument will execute its programming instructions when properly installed on that instrument. Hewlett-Packard does not warrant that the operation of the instrument, or software, or firmware will be uninterrupted or error-free.

## LIMITATION OF WARRANTY

The foregoing warranty shall not apply to defects resulting from improper or inadequate maintenance by Buyer, Buyer-supplied software or interfacing, unauthorized modification or misuse, operation outside of the environmental specifications for the product, or improper site preparation or maintenance.

NO OTHER WARRANTY IS EXPRESSED OR IMPLIED. HEWLETT-PACKARD SPECIFICALLY DISCLAIMS THE IMPLIED WARRANTIES OF MERCHANTABILITY AND FITNESS FOR A PARTICULAR PURPOSE.

## EXCLUSIVE REMEDIES

THE REMEDIES PROVIDED HEREIN ARE BUYER'S SOLE AND EXCLUSIVE REMEDIES. HEWLETT-PACKARD SHALL NOT BE LIABLE FOR ANY DIRECT, INDIRECT, SPECIAL, INCIDENTAL, OR CONSEQUENTIAL DAMAGES, WHETHER BASED ON CONTRACT, TORT, OR ANY OTHER LEGAL THEORY.

---

## Assistance

*Product maintenance agreements and other customer assistance agreements are available for Hewlett-Packard products. For any assistance, contact your nearest Hewlett-Packard Sales and Service Office.*

## Hewlett-Packard Sales and Service Offices

<b>US FIELD OPERATIONS</b>		
<p><b>Headquarters</b> Hewlett-Packard Co. 19320 Pruneridge Avenue Cupertino, CA 95014  800  752-0900</p>	<p><b>California, Northern</b> Hewlett-Packard Co. 301 E. Evelyn Mountain View, CA 94041  415  694-2000</p>	<p><b>California, Southern</b> Hewlett-Packard Co. 1421 South Manhattan Ave. Fullerton, CA 92631  714  999-6700</p>
<p><b>Colorado</b> Hewlett-Packard Co. 24 Inverness Place, East Englewood, CO 80112  303  649-5512</p>	<p><b>Atlanta Annex</b> Hewlett-Packard Co. 2124 Barrett Park Drive Kennesaw, GA 30144  404  648-0000</p>	<p><b>Illinois</b> Hewlett-Packard Co. 5201 Tollview Drive Rolling Meadows, IL 60008  708  255-9800</p>
<p><b>New Jersey</b> Hewlett-Packard Co. 150 Green Pond Rd. Rockaway, NJ 07866  201  586-5400</p>	<p><b>Texas</b> Hewlett-Packard Co. 930 E. Campbell Rd. Richardson, TX 75081  214  231-6101</p>	
<b>EUROPEAN FIELD OPERATIONS</b>		
<p><b>Headquarters</b> Hewlett-Packard S.A. 150, Route du Nant-d'Avril 1217 Meyrin 2/Geneva Switzerland  41 22  780.8111</p>	<p><b>France</b> Hewlett-Packard France 1 Avenue Du Canada Zone D'Activite De Courtaboeuf F-91947 Les Ulis Cedex France  33 1  69 82 60 60</p>	<p><b>Germany</b> Hewlett-Packard GmbH Hewlett-Packard Strasse 61352 Bad Homburg v.d.H Germany  49 6172  16-0</p>
<p><b>Great Britain</b> Hewlett-Packard Ltd. Eskdale Road, Winnersh Triangle Wokingham, Berkshire RG41 5DZ England  44 734  696622</p>		

**Hewlett-Packard Sales and Service Offices (continued)**

<b>INTERCON FIELD OPERATIONS</b>		
<p><b>Headquarters</b>                      Hewlett-Packard Company                      3495 Deer Creek Road                      Palo Alto, California, USA                      94304-1316                       415  857-5027</p>	<p><b>Australia</b>                      Hewlett-Packard Australia Ltd.                      31-41 Joseph Street                      Blackburn, Victoria 3130                       61 3  895-2895</p>	<p><b>Canada</b>                      Hewlett-Packard  Canada  Ltd.                      17500 South Service Road                      Trans-Canada Highway                      Kirkland, Quebec H9J 2X8                      Canada                       514  697-4232</p>
<p><b>China</b>                      China Hewlett-Packard Company                      38 Bei San Huan X1 Road                      Shuang Yu Shu                      Hai Dian District                      Beijing, China                       86 1  256-6888</p>	<p><b>Japan</b>                      Hewlett-Packard Japan, Ltd.                      1-27-15 Yabe, Sagamihara                      Kanagawa 229, Japan                       81 427  59-1311</p>	<p><b>Singapore</b>                      Hewlett-Packard Singapore  Pte.  Ltd.                      150 Beach Road                      #29-00 Gateway West                      Singapore 0718                       65  291-9088</p>
<p><b>Taiwan</b>                      Hewlett-Packard Taiwan                      8th Floor, H-P Building                      337 Fu Hsing North Road                      Taipei, Taiwan                       886 2  712-0404</p>		



---

## How to Use This Guide

### **This guide uses the following conventions.**

- Front-Panel Key** This represents a key physically located on the instrument.
- Softkey** This indicates a “softkey,” a key whose label is determined by the instrument’s firmware.
- Screen Text** This indicates text displayed on the instrument’s screen.

---

## Documentation Description

This manual contains information on operating, testing, and servicing the HP 86200B and HP 86201B RF detectors. Figure 1-1 shows the detectors.

# Notice

---

## **Hewlett-Packard to Agilent Technologies Transition**

This documentation supports a product that previously shipped under the Hewlett-Packard company brand name. The brand name has now been changed to Agilent Technologies. The two products are functionally identical, only our name has changed. The document still includes references to Hewlett-Packard products, some of which have been transitioned to Agilent Technologies.



---

# Contents

<b>1. General Information</b>	
Product Description . . . . .	1-3
Specifications and Supplemental Characteristics . . . . .	1-4
Operating Environment . . . . .	1-6
Accessories . . . . .	1-6
Storage and Shipment . . . . .	1-7
Environment . . . . .	1-7
Packaging . . . . .	1-7
Returning a Detector for Service . . . . .	1-8
<b>2. Installation</b>	
Initial Inspection . . . . .	2-3
Electrostatic Discharge (ESD) . . . . .	2-4
Static-Safe Work Station . . . . .	2-4
Static-Safe Practices . . . . .	2-5
Power Requirements . . . . .	2-6
Mating Connectors . . . . .	2-7
Connecting the Detector . . . . .	2-8
<b>3. Operation</b>	
Features . . . . .	3-3
Operator's Check . . . . .	3-4
Procedure 1, Measuring a Bandpass Filter . . . . .	3-5
Procedure 2, Viewing the Calibration Constants . . . . .	3-7
If the Operator's Check Fails . . . . .	3-8
Zeroing the Detector . . . . .	3-9
Example Measurements . . . . .	3-11
Insertion Loss Measurement . . . . .	3-11
AM Delay Measurement . . . . .	3-12

<b>4. Performance Tests</b>	
Equipment Required . . . . .	4-3
Return Loss Test . . . . .	4-5
To Set Up the Equipment . . . . .	4-5
Measurement Procedure . . . . .	4-7
If This Test Fails . . . . .	4-8
<b>5. Adjustments</b>	
<b>6. Replaceable Parts</b>	
How To Order Parts Fast . . . . .	6-3
<b>7. Service</b>	
Replacing the Connector Assembly . . . . .	7-4
<b>8. Caring for Connectors</b>	
Visual Inspection . . . . .	8-3
Cleaning . . . . .	8-4
Mechanical Inspection . . . . .	8-5

**Index**

---

## Figures

1-1. Detector . . . . .	1-3
2-1. Example of a Static-Safe Work Station . . . . .	2-5
3-1. Detector Features . . . . .	3-3
3-2. Typical Waveform of a Bandpass Filter . . . . .	3-6
3-3. Setup for Insertion Loss or AM Delay Measurement . . . . .	3-11
4-1. Setup for Return Loss Test . . . . .	4-6
6-1. Detector . . . . .	6-4
7-1. Removing the Connector . . . . .	7-3

---

## Tables

1-1. HP 86200B/86201B RF Detector Specifications . . . . .	1-4
1-2. Supplemental Characteristics . . . . .	1-5
3-1. Equipment for Operator's Check . . . . .	3-4
4-1. Recommended Equipment . . . . .	4-4
4-2. Return Loss Equipment Table . . . . .	4-5
4-3. HP 86200B/86201B Test Record (1 of 3) . . . . .	4-8
6-1. Replaceable Parts & Accessories . . . . .	6-4

## Contents

| \_

---

| \_

---

## General Information



---

## General Information

This manual contains information on operating, testing, and servicing the HP 86200B and HP 86201B RF detectors. Figure 1-1 shows the detectors.

---

## Product Description

The HP 86200B and 86201B RF detectors are specifically designed for use with HP 8711B/C, HP 8712B/C, HP 8713B/C, HP 8714B/C RF network analyzers. They are not compatible with scalar network analyzers such as the HP 8757 series. These detectors can be used with an HP 8711A analyzer, as long as the analyzer has firmware revision 3.0 or above.

HP Detector	Connector Type
HP 86200B	50 $\Omega$ Type-N(m)
HP 86201B	75 $\Omega$ Type-N(m)

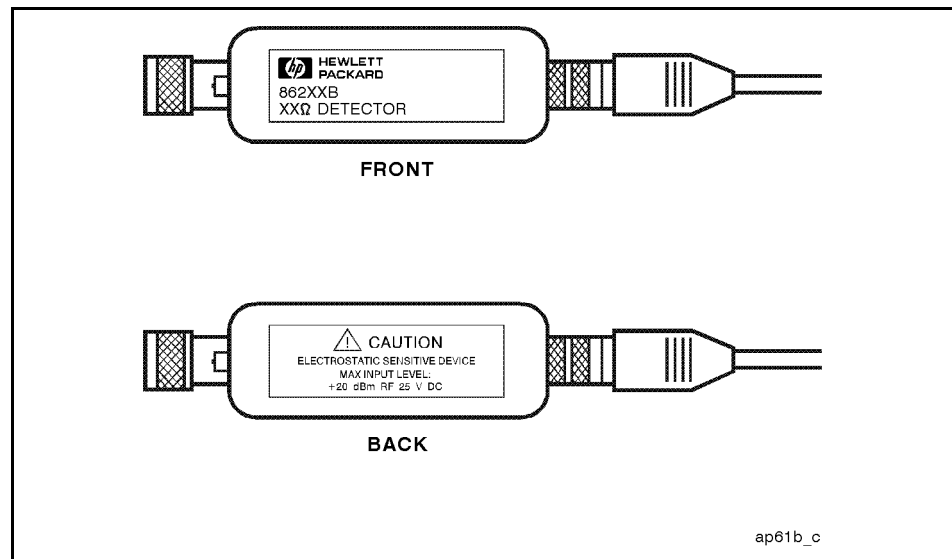

Figure 1-1. Detector

# Specifications and Supplemental Characteristics

Table 1-1 lists detector specifications, when used with an HP 8711B/C, HP 8712B/C, HP 8713B/C, HP 8714B/C analyzer, which are the warranted performance standards or limits against which you can test the device.

Table 1-2 lists supplemental (typical, non-warranted) detector characteristics, when used with one of the above-mentioned analyzers.

**Table 1-1. HP 86200B/86201B RF Detector Specifications**

Specifications describe the instrument's warranted performance over the temperature range of  $25 \pm 5^\circ\text{C}$ .

<b>Connector:</b>	Type-N m
<b>Frequency Range:</b>	10 MHz to 3.0 GHz
<b>Nominal Impedance:</b>	
HP 86200B:	50 $\Omega$
HP 86201B:	75 $\Omega$
<b>Return Loss:</b>	
10 MHz to 1.3 GHz:	$\geq 22$ dB
1.3 MHz to 3.0 GHz:	$\geq 18$ dB
<b>Frequency Response:</b> <sup>1</sup>	
10 MHz to 3 GHz:	$\pm 0.5$ dB at 0 dBm
<b>Absolute Power Accuracy for the HP 86200B</b> (30 MHz):	
<b>Power (dBm)</b>	<b>Accuracy (<math>\pm</math>dB)</b>
+16	$\pm 1.55$
+10	$\pm 1.50$
-30	$\pm 1.50$
-40	$\pm 2.00$
-50	$\pm 3.00$
<b>Absolute Power Accuracy for the HP 86201B</b> (30 MHz):	
<b>Power (dBm)</b>	<b>Accuracy (<math>\pm</math>dB)</b>
+16	$\pm 1.55$
+10	$\pm 1.50$
-30	$\pm 1.50$
-40	$\pm 2.00$
-47	$\pm 2.70$

<sup>1</sup> This specification for the HP 86201B is typical above 2.0 GHz.

**Table 1-2. Supplemental Characteristics**

<b>Cable Length:</b>	2.0 m [6.56 in.]
<b>Weight</b> (Including cable):	
Net:	0.34 kg [0.75 lb]
Shipping:	0.57 kg [1.25 lb]
<b>AM Delay Dynamic Accuracy:</b> <b>Normalized at 10 dBm</b>	
Power Deviation from Normalization	
0 dB to 10 dB	$\pm 10$ ns
10 dB to 20 dB	$\pm 20$ ns
<b>Recommended Power Range for AM Delay Measurement</b>	-10 dBm to +13 dBm
<b>Dynamic Range:</b>	
HP 86200B	-50 dBm to +16 dBm
HP 86201B	-47 dBm to +16 dBm
<b>RF Connector Mechanical Tolerances</b>	
HP 86200B nominal impedance:	50 $\Omega$
HP 86201B nominal impedance:	75 $\Omega$
Recession of the male center conductor from reference plane:	0.207 to 0.210 in <sup>1</sup>

<sup>1</sup> Because a Type-N gauge calibration block zeros the gauge at a 0.207 inch offset, the gauge displays a 0.207 to 0.210 inch offset as 0.000 to 0.003 inches.

---

## Operating Environment

The detector will operate safely under the following conditions, but its performance is not necessarily warranted. See the specifications section for more information.

**Temperature:** 0° to +55°C.

**Humidity:** Up to 95%. Protect the detector from temperature extremes, which can cause condensation.

**Altitude:** Up to 4,572m (15,000 ft).

---

## Accessories

The detectors come with a 2 meter cable. A 20 meter cable can be ordered separately. Table 6-1 lists accessories available for use with these detectors.

---

## Storage and Shipment

To keep your detector in proper working condition, store or ship it keeping the following suggestions in mind.

---

## Environment

Store or ship the detectors in environments within the following limits:

Temperature:  $-25^{\circ}$  to  $+75^{\circ}\text{C}$ .

Humidity: Up to 95%. Protect the detector from temperature extremes which can cause condensation.

Altitude: Up to 4,572m (15,000 ft).

---

## Packaging

Use containers and materials identical or comparable to those used in factory packaging. If you to ship the detector, follow these packaging instructions:

1. Wrap the detector in the original pouch and box. If they are not available, then wrap the detector in heavy paper and use a strong shipping container.
2. Provide a firm cushion that prevents movement inside the container.
3. Use a layer of shock-absorbing material around all sides of the detector.
4. Seal the shipping container securely.
5. Mark the shipping container *FRAGILE*.

---

## Returning a Detector for Service

When you make an inquiry, either by mail or by telephone, refer to the detector by both model number and full serial number.

If you ship the detector to a Hewlett-Packard office or service center, fill out a blue service tag (provided at the back of this manual), and include the following information:

1. Company name and address.  
*Do not* use an address with a P.O. box number because products cannot be returned to a P.O. box.
2. A technical contact person with a complete phone number.
3. The complete model and serial number of the detector.
4. The type of service required (calibration, repair).
5. Any other information that could expedite service, such as failure condition or cause.

**Installation**



---

## Installation

Refer to the following information when using the detector. Do not drop the detector or subject it to excessive mechanical shock.

---

## Initial Inspection

1. Check the shipping container and packaging material for damage.
2. Check that the shipment is complete.
3. Check connector, cable, and detector body for mechanical damage.
4. Check the detector electrically:

Either perform the operator's check in Chapter 3, "Operation" or make a measurement in Chapter 4, "Performance Tests".

If any of the following conditions exist, notify your nearest Hewlett-Packard office:

- Incomplete shipment.
- Mechanical damage or defect.
- Failed electrical test.

If you find damage or signs of stress to the shipping container or the cushioning material, keep them for the carrier's inspection. Hewlett-Packard does not wait for a claim settlement before arranging for repair or replacement.

---

## Electrostatic Discharge (ESD)

ESD can damage the highly sensitive circuits in this device; charges as low as 100V can destroy a detector. ESD damage occurs most often as you connect or disconnect a device. Use this detector at a static-safe workstation and wear a grounding strap. *Never* touch the input connector center contacts or the cable contact pins.

---

## Static-Safe Work Station

Figure 2-1 illustrates a static-safe station using two types of ESD protection that you can use either together or separately (see Table 6-1 for ordering information):

- A conductive table mat and wrist-strap combination.
- A conductive floor mat and heel-strap combination.

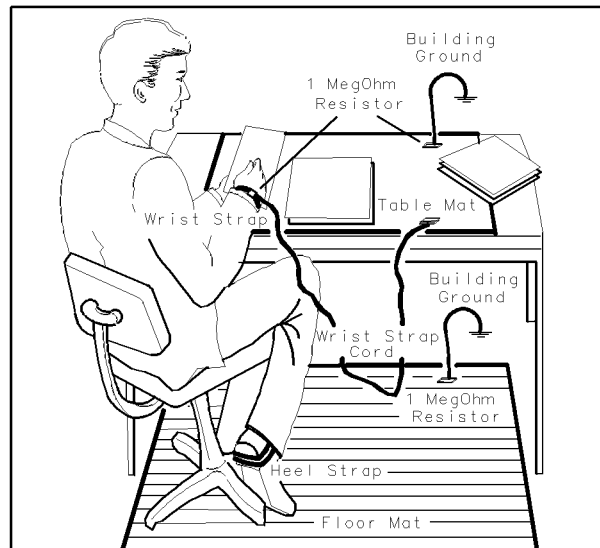

FORMAT46

**Figure 2-1. Example of a Static-Safe Work Station**

---

## Static-Safe Practices

- Before cleaning, inspecting, or making a connection to a static-sensitive device or test port, ground yourself as far as possible from the test port.
- Discharge static electricity from a device before connecting it: Touch the device briefly (through a resistor of at least 1 M $\Omega$ ) to either the outer shell of the test port, or another exposed ground. This discharges static electricity and protects test equipment circuitry.

---

## Power Requirements

The analyzer supplies power for the detector.

---

## Mating Connectors

Table 1-2 lists connector mechanical tolerances. *Microwave Connector Care* (HP part number 08510-90064) provides information on the proper maintenance, inspection, and gaging of connectors.

---

## Connecting the Detector

1. The HP 86200B and HP 86201B cables plug into the connectors on the rear panel of the analyzer. They are labeled EXT DET X-INPUT and EXT DET Y-INPUT. With the cable plug key downward, insert the multi-pin (DC) connector into either external detector input on the rear panel of the analyzer.
2. To secure the DC connector in the analyzer, turn the *outer* shell clockwise.
3. Connect the RF input to the test device by turning the type-N male connector *outer* shell clockwise.

**————** Operation



---

## Operation

### **CAUTION**

- Electrostatic discharge (ESD) can damage the highly sensitive circuits in this device; charges as low as 100V can destroy your detector.
- ESD damage occurs most often as you connect or disconnect a device. Use this detector at a static-safe workstation and wear a grounding strap. *Never* touch the input connector center contacts, or the cable contact pins.
- Do *not* apply more than +20 dBm RF power or more than  $\pm 25$  VDC to the detector. Higher power/voltage can electrically damage the detector.
- Before you connect a RF cable to the detector, always discharge the cable's outer conductor static electricity to instrument ground. This is most important if the cable is very long or connected to a large antenna.
- Do not drop the detector or subject it to mechanical shock.

---

## Features

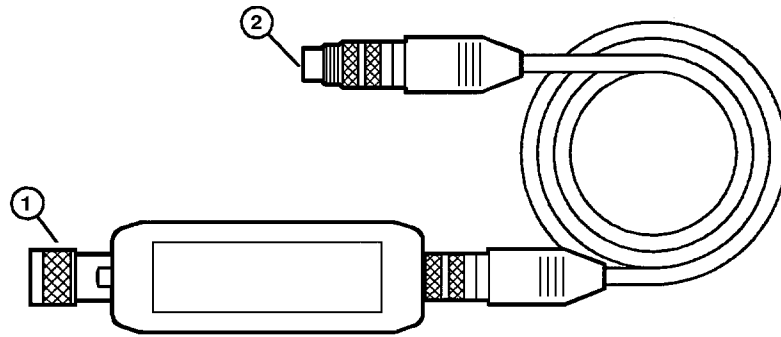

1. **RF INPUT CONNECTOR:** This connector accepts an RF input signal. The RF input connector varies with the detector selected.
2. **DC CONNECTOR:** This connector supplies the necessary DC voltage for operation of the detector, and feeds the detector output signal to the network analyzer.

ap64b\_c

**Figure 3-1. Detector Features**

---

## Operator's Check

The following two procedures provide a quick operational check of the HP 86200B or HP 86201B RF detector.

**Table 3-1. Equipment for Operator's Check**

Detector	Equipment
HP 86200B	HP 8711B/C, HP 8712B/C, HP 8713B/C, HP 8714B/C network analyzer 175 MHz Bandpass filter, 0955-0759 <sup>1</sup>
HP 86201B	HP 8711B/C, HP 8712B/C, HP 8713B/C, HP 8714B/C network analyzer with Option 1EC (75 $\Omega$ ports) 175 MHz Bandpass filter, 0955-0760 <sup>1</sup>

<sup>1</sup> The bandpass filter is shipped with each analyzer. Other filters may also be used within the frequency range of the analyzer.

---

## Procedure 1, Measuring a Bandpass Filter

1. Connect the detector cable to the EXT DET X INPUT on the rear panel of the analyzer.
2. Connect the detector's RF connector to the REFLECTION port of the analyzer.
3. On the analyzer, press the following keys to set up the analyzer to measure the X input across the broadband frequency range:

**PRESET**  
**FREQ**  
Start **10** MHz  
**AVG**  
System Bandwidth  
Narrow 250 Hz  
**CHAN 1** or **MEAS 1**  
Detection Options  
Broadband External  
X

4. Press: **SCALE** **0.5** **ENTER** and check the peak-to-peak variation of the trace. The variation should be less than 3 dB.
5. Press: **FREQ** Stop **400** MHz
6. Press: **CAL** **Normalize** to remove the frequency response effects.
7. Insert the bandpass filter.

Operation

### Operator's Check

- Press **SCALE** **10** **ENTER** **Reference Level** **7** **ENTER**.
- Verify that the waveform displayed on the screen is similar to that shown below.

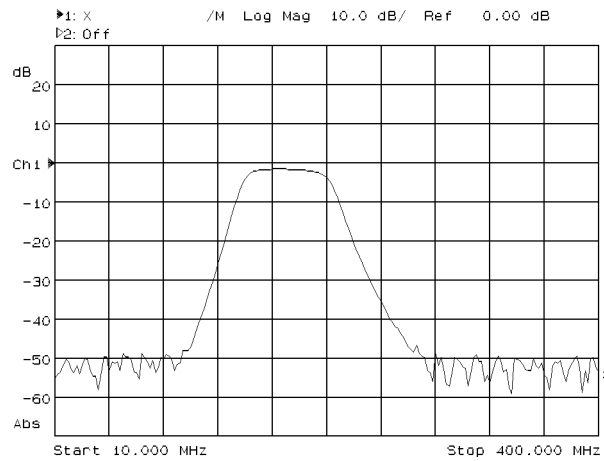

**Figure 3-2. Typical Waveform of a Bandpass Filter**

---

## Procedure 2, Viewing the Calibration Constants

1. On the analyzer, press the following keys to set up the analyzer to interrogate the X detector's calibration constants.

### **NOTE**

Be sure the X detector is connected to the rear panel of the analyzer. If it is not connected, the table will show the default calibration constants. Also, be sure the analyzer takes at least one sweep after connecting the detector. The analyzer must take at least one sweep before the table is updated with the current detector's calibration constants.

#### SYSTEM OPTIONS

Service

Service Utilities

More Service Utilities

Ext Det Info

X AM Delay Cal Table

2. You should see, on your analyzer display, a list of the calibration coefficients stored in the EEPROM in your detector. The model and serial number for your detector should also be displayed at the top of the screen.

This procedure is only a functional test to make sure that the detector is transferring its cal constant values to the analyzer. This procedure does not test the accuracy or validity of the cal constant values.

---

## If the Operator's Check Fails

Since the detector is measuring from the output of the analyzer's internal source, problems may be due to the source, rather than the detector. Verify that the source output as well as the bandpass filter waveform are accurate. Note that bandpass filters can vary considerably from unit to unit. If the average noise floor is not below  $-45$  dB, try zeroing the detector. The instructions for zeroing the detector are on the following page.

---

## Zeroing the Detector

1. You can connect detectors into either the X or Y input.
2. Select desired measurement by pressing:

**CHAN 1** or **CHAN 2** or **MEAS 1** or **MEAS 2**

**Detection Options**

**Broadband External**

3. Select one of these:

**X**, **Y**, **Y/X**, **X/Y**

When making measurements, you must perform a zeroing operation to compensate for the effects of DC drift and temperature fluctuations. The zeroing operation eliminates the effects of the small DC voltages present in the detector that would otherwise cause amplitude measurement errors at low power levels (−35 dBm and below). Zeroing also establishes the displayed noise level (the system noise floor) with no RF signal applied.



## Operator's Check

### Types of Zeroing

There are two types of zeroing:

**Manual Zero** Manual zero is similar to power meter zeroing. The manual zero mode zeros once each time the key is pressed. If the analyzer source is being used as the stimulus, it will automatically be turned off when the detectors are being zeroed. If an external source is being used, the user must remove or turn it off when the detector is zeroed. Because of this, manual zero mode is more appropriate when an external source is in use.

**Autozero** The default autozero mode turns off the analyzer source RF signal output and zeros the detector every five minutes.

#### NOTE

Before you zero the detector, remove *all* RF signals from the detector input. Even a small RF signal present during zeroing produces measurement errors.

To select the zeroing mode, press the following keys:

**CAL**

**Detector Zero**

Choose either:

**Autozero** or

**Manual Zero**

#### NOTE

See the analyzer's *User's Guide* for more information on these softkeys.

---

## Example Measurements

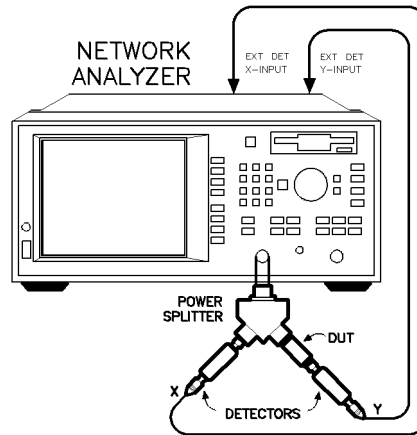

Figure 3-3. Setup for Insertion Loss or AM Delay Measurement

---

## Insertion Loss Measurement

1. Connect the equipment as shown in the previous illustration.
2. Set the parameters on the analyzer to measure with an external detector by pressing:  
**PRESET**  
**CHAN 1** or **MEAS 1**  
**Detector Options**  
**Broadband External**  
**Y/X**
3. This will display the approximate insertion loss of the device under test. If more accuracy is required, remove the DUT and normalize the resulting through line response.

---

## AM Delay Measurement

Your analyzer must have option 1DA or 1DB installed to perform AM delay measurements.

1. Connect the equipment as shown in the previous illustration.
2. Set the parameters on the analyzer to measure with external detectors by pressing:

PRESET

BEGIN

Mixer

AM Delay

### NOTE

For best accuracy, an AM Delay user calibration should be performed before making the measurement. Refer to the analyzer's *User's Guide* for more information.

---

## Performance Tests

---

## Performance Tests

Use the procedures in this chapter to test the detector's electrical performance to the specifications listed in Chapter 1. None of these tests require access to the detector's interior. To completely test each detector, one manual and two automated tests are required:

1. return loss (manual)
2. frequency response (automated)
3. power/dynamic accuracy (automated)

Use the software (part number 08712-10011 for analyzer model numbers ending with a "B"; 08712-10017 for analyzer model numbers ending with a "C") to perform the frequency response and power accuracy tests. (Note: This software must be ordered separately. See "Replaceable Parts.") For automated testing, an HP 9000 series 200/300 computer (or equivalent) is required. The return loss test is not automated and must be performed manually.

Perform the two required automated tests and attach the printed results to the test record card.

---

## Equipment Required

Preceding each test is an equipment table that lists which equipment you will need for that particular test. You may substitute any equipment that meets the indicated critical specifications. See the following table for a list of required equipment

**NOTE**

Before you perform a performance test, gage the input connector on the detector and enter the results in the test record at the end of "Performance Tests." For descriptive illustrations defining connector tolerances, see *Microwave Connector Care* (HP part number 08510-90064).

Performance Tests  
**Equipment Required**

**Table 4-1. Recommended Equipment**

Description	Requirements	Recommended Model
HP 9000 series 200/300 Controller or equivalent	No Substitute	ANY
BASIC 5.0 or higher	No substitute	HP 98618B
Test Software	No substitute	HP P/N 08712-10011
RF Network Analyzer <sup>1</sup>	No substitute	HP 8713BC/14BC
Power Meter	No substitute	HP 437B, 438A
Power Sensors: 50 ohm  75 ohm	Freq: 300 kHz to 3.0 GHz Power Range: -30 to +20 dBm  Freq: 300 kHz to 2.0 GHz Power Range: -30 to +20 dBm Impedance: 75Ω [HP 86201B only]	HP 8482A  HP 8483A <sup>2</sup>
Step Attenuator	70 dB range in 10 dB steps	ANY
Function Generator	No substitute	HP 8116A
Attenuator/Switch Driver	Required for the HP 8496G attenuator only	HP 11713A
Type-N Calibration Kit	No substitute	HP 85032B <sup>3</sup> , HP 85036B <sup>2</sup>
Power Splitters: 50 ohm <sup>3</sup> 75 ohm <sup>2</sup>	Freq: 300 kHz to 3 GHz  Freq: 300 kHz to 3 GHz	HP 11667A, 0955-0751 0955-0752
Minimum Loss Pad <sup>2,4</sup>	No substitute	HP 11852B
Adapters: Type-N [f] to Type-N [f]  BNC [m] to Type-N [f]	75 ohm  50 ohm	HP P/N 85036-60014 [p/o HP 85036B] HP P/N 1250-0077
HP-IB Cables [3 or 4]	No substitute	HP 10833A/B/C

<sup>1</sup> If an HP 8711B/C, HP 8712B/C is used the detectors will only be tested to 1.3 GHz.

<sup>2</sup> Needed only for HP 86201B.

<sup>3</sup> Needed only for HP 86200B.

<sup>4</sup> For convenience, an HP 11852B Option 004 is also recommended for testing the HP 86201B.

---

## Return Loss Test

This performance test uses an HP 8713B/C, HP 8714B/C system to measure the return loss of the detector.

Return loss specification:

≥ 22 dB, 10 MHz to 1.3 GHz

≥ 18 dB, 1.3 GHz to 3.0 GHz

---

## To Set Up the Equipment

The list below show the equipment used in this test. You can use any equipment that meets the critical specifications. However, the procedure is based on the recommended model or part number. Warm-up time is one hour.

**Table 4-2. Return Loss Equipment Table**

Equipment	Recommended HP Model or Part Number	
	For the HP 86200B	For the HP 86201B
Network analyzer	HP 8713B/C, HP 8714B/C	HP 8713B/C, HP 8714B/C
Type-N calibration kit	HP 85032B/E	HP 85036B/E

### **NOTE**

If you have a 50Ω analyzer and a 75Ω detector or a 75Ω analyzer and a 50Ω detector, a minimum loss pad will be required on the reflection port of the analyzer. Use an HP 11852B Option 004 or HP 11852B respectively.



Performance Tests  
**Return Loss Test**

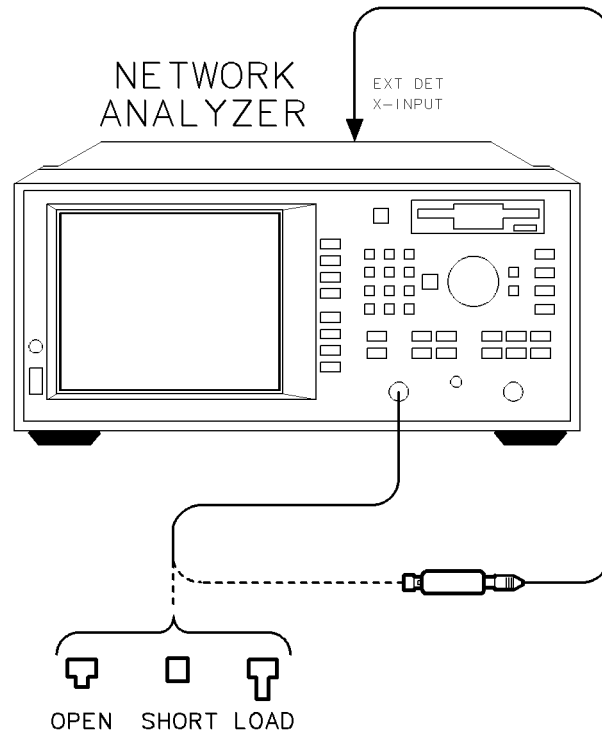

**Figure 4-1. Setup for Return Loss Test**

---

## Measurement Procedure

Calibrate your measurement system.

1. On the analyzer, press:
2. **PRESET**
3. **CHAN 1** or **MEAS 1** **Reflection**
4. **FREQ** **Start** **10** **MHz**
5. **CAL** **Reflection** **One Port**
6. The analyzer will prompt you to connect three standards to the reflection port.
7. Press **Measure Standard** after connecting each standard.
8. The analyzer will measure each standard and then calculate new calibration coefficients. The message **Calibration complete.** will appear for a few seconds when the analyzer is done calculating the new error correction array.

Make your measurement

1. Connect the detector under test to the reflection port.
2. Press **MARKER** and rotate the front panel knob to find the worst case return loss over the frequency range up to 1300 MHz. Record these values in the test record card at the end of this chapter.
3. Repeat the measurement for the 1300 to 3000 MHz range.

---

## If This Test Fails

Check the type-N connector on the detector to make sure there is no damage. Open the detector's case and check the connection between the type-N connector and the PC board. Check that the detector is connected securely to the rear panel of the analyzer. Replace the connector if necessary. If the detector still fails, refer to the "Service" chapter for more troubleshooting information.

**Table 4-3. HP 86200B/86201B Test Record (1 of 3)**

Test Facility _____	Report Number _____
_____	Date _____
_____	Customer _____
_____	Tested by _____
Model _____	Ambient temperature _____ °C
Serial Number _____	Relative humidity _____ %
Options _____	
Special Notes	
_____	
_____	

**Table 4-3. HP 86200B/86201B Test Record (2 of 3)**

Model _____ Report Number _____ Date _____			
<b>Test Equipment Used</b>	<b>Model Number</b>	<b>Trace Number</b>	<b>Cal Due Date</b>
1. _____	_____	_____	_____
2. _____	_____	_____	_____
3. _____	_____	_____	_____
4. _____	_____	_____	_____
5. _____	_____	_____	_____
6. _____	_____	_____	_____
7. _____	_____	_____	_____
8. _____	_____	_____	_____

**Table 4-3. HP 86200B/86201B Test Record (3 of 3)**

<b>Serial Number:</b>	<b>Report Number:</b>		<b>Date:</b>
<b>Test Description</b>	<b>Specification</b>	<b>Measured Results</b>	<b>Measurement Uncertainty<sup>1</sup></b>
<b>Return Loss</b>			
10 MHz to 1.3 GHz	≥ 22 dB	_____	±1.4 dB
1.3 GHz to 3.0 GHz	≥ 18 dB	_____	±1.1 dB

<sup>1</sup> Using the equipment and procedures documented in this manual.

<b>Connector Pin Depth (typical)</b>	<b>Minimum Value</b>	<b>Measured Results</b>	<b>Maximum Value</b>
RF Port	0.207 in.	_____	0.210 in.

**Adjustments**

---

## Adjustments

There are no adjustments which can be performed on the HP 86200B or HP 86201B. The detectors are calibrated at the factory and the calibration data is stored in a EEPROM in the detector.

The analyzer's "External Detector Correction" improves detector measurements by calibrating the receiver for specific DC voltages from the external detector inputs. Refer to the analyzer's service guide for more details.

**Replaceable Parts**



---

## Replaceable Parts

This chapter provides replaceable parts and ordering information. To order a part listed in the replaceable parts Table 6-1, quote the Hewlett-Packard part number, indicate the quantity required and address the order to your nearest Hewlett-Packard office.

To request information on a part that is not listed in the replaceable parts table, include the instrument model number and a description of the part and its function. Address the inquiry to the nearest Hewlett-Packard office.

---

## How To Order Parts Fast

When you know which parts you need to repair the detector, contact Hewlett-Packard's direct ordering team by calling the following toll-free number:

(800) 227-8164 Monday through Friday, 6am to 5pm (Pacific Standard Time).

The parts specialists have direct online access to replacement parts inventory corresponding to the Replaceable Parts table in this manual. There is a charge for hotline one day delivery, but four day delivery time is standard. After hours and holidays, call (415) 968-2347.

This information applies to the United States only. Outside the United States, contact your nearest HP office.

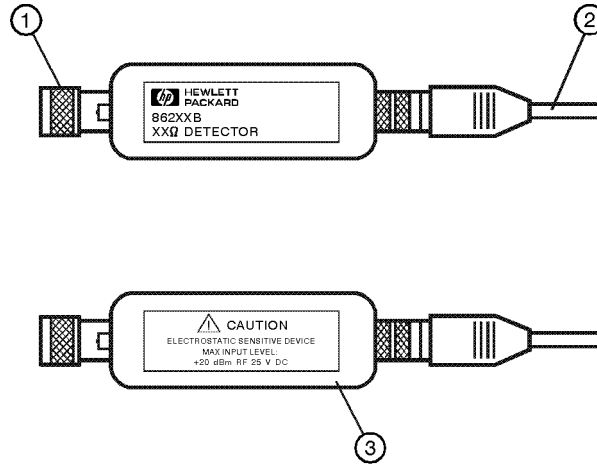

ap62b\_c

Figure 6-1. Detector

Table 6-1. Replaceable Parts & Accessories

ITEM #	Part	Description	Part Number
	Replacement HP 86200B 50Ω Detector		86200-60009
	Replacement HP 86201B 75Ω Detector		86201-60009
1	50Ω Connector Assembly	Type-N	86200-60003
1	75Ω Connector Assembly	Type-N	86201-60001
2	Cable 2m		8120-5514
	Cable 20m		8120-5515
3	Label:Warning		86200-80002
	Screws  quantity-3		0515-0662
	Clip Shield		86200-00006
	Halfbody top		86200-40001
	Halfbody bottom		86200-40002
	Test Software		08712-10011
	50Ω Adapter Kit	Type-N to 3.5 mm	HP 11878A
	50Ω Adapter Kit	Type-N to BNC	HP 11854A
	50Ω Adapter Kit	Type-N to TNC	HP 86212A
	75Ω Adapter Kit	Type-N to BNC	HP 11856A
	75Ω Adapter Kit	Type-N to Type-F	HP 86211A

**Service**

---

## Service

---

**CAUTION**

---

This product is susceptible to damage from electrostatic discharge (ESD). When you perform any of the following procedures, wear a grounded static-strap and work at a static-safe work station.

If the detector fails electrically, order a replacement detector. Do not order the detector using its model number (HP 86200B or HP 86201B). Instead use the replacement part number given in Table 6-1 that is referenced to the model number.

These detectors have the following replaceable items:

- The input connector.
- The cable assembly.

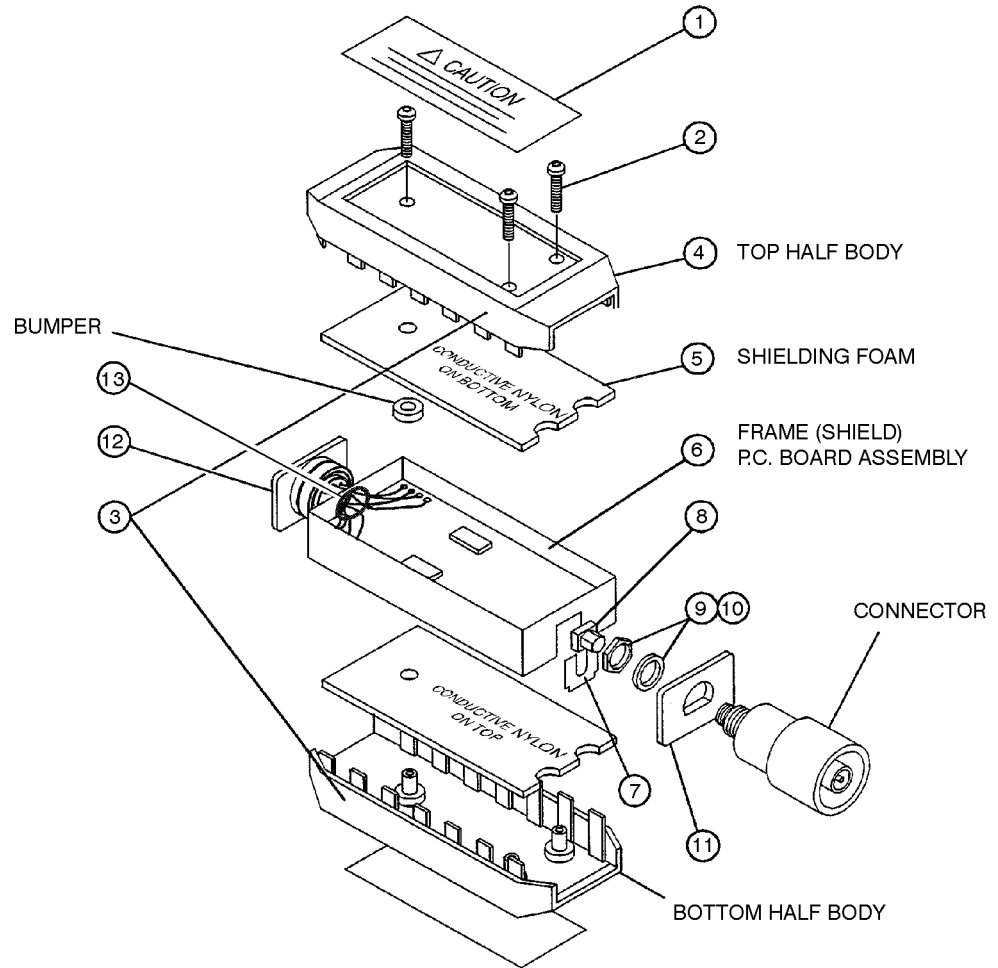

ap63b\_c

Figure 7-1. Removing the Connector

---

## Replacing the Connector Assembly

- a. Remove the ESD warning label (1).
- b. Remove the three screws (2).
- c. Pull the half bodies apart (3).
- d. Remove the top half body lid (4).
- e. Lift the frame (shield) PC board assembly (6) off the bottom half body.
- f. Set the bodies aside.
- g. Using a 5/16 inch torque wrench, loosen the SMA connector nut on the PC board (8).
- h. Using a 9/16 inch nut driver, remove the nut (9) and washer (10).

To put on the new connector reverse these steps and use:

- A 9/16 inch, 35 to 40 in-lb torque wrench for the connector nut.
- A 5/16 inch, 10 in-lb torque wrench for the SMA connector on PC board.
- A 3 in-lb torque for torque screws (2).

### **NOTE**

Ensure that the male pin of the connector is carefully aligned with the connector on the board to prevent damage to the connectors, and that the clip shield (7) is positioned properly before torquing the connector. The PC board assembly (6) should be parallel with the bottom edge of the front bulkhead (11) after the SMA nut is tightened. Compress the rear bulkhead assembly (12) against the frame (6) with your thumb while inserting the assembly into the bottom half body (3). Reposition the spring gasket (13) against the bulkhead assembly. Be careful not to pinch the cable wires in the frame or half-bodies when assembling.

---

## Caring for Connectors



---

## Caring for Connectors

This chapter provides a brief introduction to the fundamentals of proper connector care, as important to good measurements as proper instrument calibration and adjustment. For more information, refer to Hewlett-Packard's *Microwave Connector Care* manual (HP part number 08510-90064).

**Remember**

A damaged connector can destroy any connector attached to it.

Basic connector care consists of three parts:

1. visual inspection
2. cleaning
3. mechanical inspection

---

## Visual Inspection

Visually inspect all system connectors often. Examine connectors for problems such as contamination or corrosion, especially on the contacting surfaces. Look for deformed threads, burrs, scratches, rounded shoulders, and similar signs of wear or damage. Any visible problem can degrade performance; clean, reinspect, and, if necessary, replace the connector.

---

## Cleaning

- Try compressed air first.

Use compressed air to loosen particles on the connector mating plane surfaces. Clean air cannot damage a connector, or leave particles or residues behind.

- If a solvent is necessary, use *only* isopropyl alcohol.

If there is dirt or contamination on a connector that you cannot removed with compressed air, try a foam swab or lint-free cleaning cloth moistened with isopropyl alcohol.

- Use the least amount of alcohol possible.
- Avoid getting any plastic parts in the connectors wet with the alcohol.
- Never spray alcohol directly into a connector.
- Check the alcohol periodically for contamination.

---

## Mechanical Inspection

Because coaxial connector mechanical tolerances can be very precise, even a perfectly clean, unused connector can cause trouble if it is mechanically out of specification. Use a connector gauge to mechanically inspect coaxial connectors. gauge a connector at the following times:

- Before you use it for the first time.
- If either visual inspection or electrical performance indicates that the connector interface may be out of specification (due to wear or damage, for example).
- The device is used on another system or piece of equipment.
- As a matter of routine: initially after every 100 connections, and after that as often as experience suggests.

Caring for Connectors

| \_

---

| \_

---

|  
—

---

**Index**

|  
—

---

# Index

- A** adjustments, 4-10
  - AM Delay measurement, 3-12
  
- C** cable
  - lead identification, 2-6
  - cleaning connectors, 8-3
  - connector
    - care, 8-2
    - cleaning, 8-3
    - mating, 2-6
    - mechanical inspection, 8-4
    - replacing, 7-4
    - visual inspection, 8-2
  
- D** detector
  - connecting, 2-7
  - replacing, 7-3
  
- E** electrostatic discharge (ESD), 2-3
  - cautions, 3-2
  
- F** floor mat
  - use, 2-4
  
- H** heel strap
  - use, 2-4
  
- I** initial inspection, 2-2
  - Insertion Loss measurement, 3-11
  - installation, 1-8

- M** mat  
use, 2-4  
measurement, AM Delay, 3-12  
measurement, Insertion Loss, 3-11  
measurement system configuration, 3-11
- O** operating environment, 1-5  
ordering parts, 6-2
- P** packaging, 1-7  
performance tests, 3-12  
power  
requirements, 2-5
- R** replaceable parts, 6-2  
replacing  
connector, 7-4  
detector, 7-3  
return loss  
test description, 4-5
- S** service, 6-4  
returning detector for service, 1-7  
setup  
AC detection mode, 3-11  
DC detection mode, 3-11  
static-safe  
practices, 2-5  
work station, 2-4  
storage and shipment, 1-6  
environment, 1-7
- T** table mat  
use, 2-4  
Test Record, 4-8
- W** wrist strap  
use, 2-4
- Z** zeroing, 3-10  
autozero, 3-10  
manual zero, 3-10



